

PRODUCT SPECIFICATIONS*

Material	Powdercoated Aluminium
Size	Medium: Ø560 x 80 mm - 1'10" x 3,15" Large: Ø800 x 80 mm - 2'7,5" x 3,15"
Weight	Aluminium Medium: 3,5 kg - 7,5 lbs Aluminium Large: 4,5 kg - 10 lbs
Power consumption	max. 150 W
Voltage	100-240 VAC - 50Hz
Connection	Hardwired, G3x1 mm ² type H05RN-F recommended
Light source	Custommade LED, 16,4W/m, 140LED/m, 1400LM/m, 2700K, 24VDC CRI>85, Beam Angle 270°
Classification	Ingress protection IP65 (LED) CE Marking, EMC, LVD All components are CE and uL certified
Maintenance	Maintenance free wipe fresh stains with a damp cloth
Warranty	Warranty of 5 year after registration

FINISHES

LIGHT GREY C31		RUST RAME C32	
BRONZE C33		BLACK BROWN C34	
MOUNTAIN MOSS C35		IVORY C36	
CUSTOM RAL			

* custom solutions on request, ask us about it!

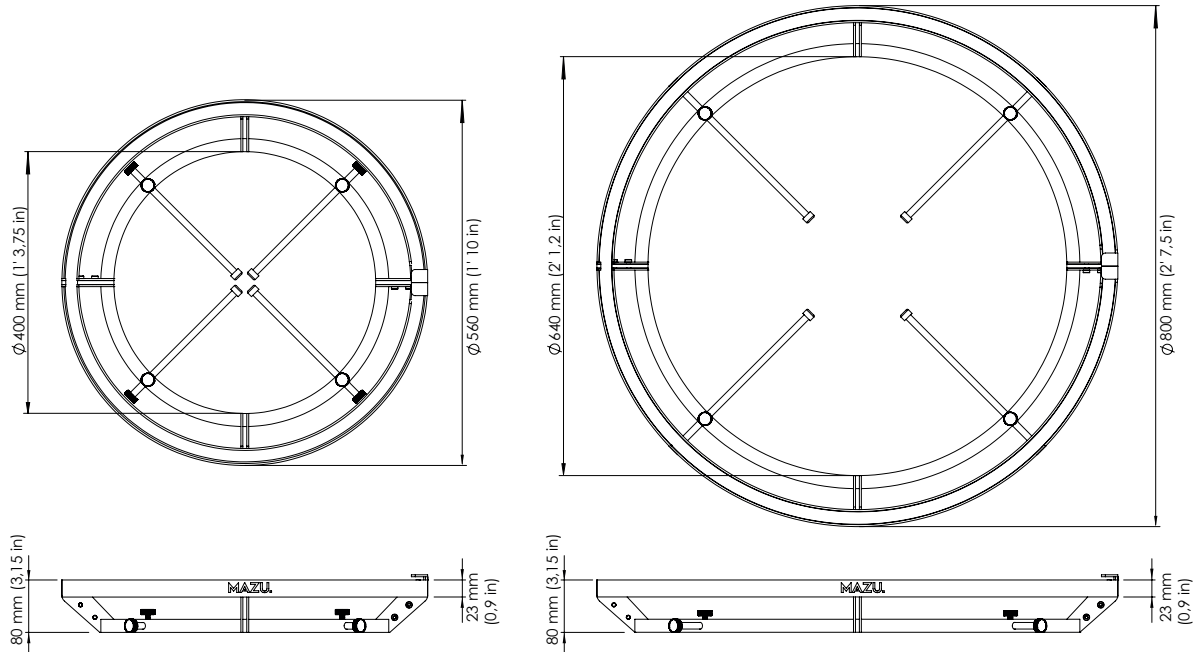

DRIVER SPECIFICATIONS (OPTIONAL)*

Specifications	Bluetooth transmission technology, low power consumption
Dimmer	Fully Dimmable, control brightness/saturation
Classification	Ingress protection IP67 (DRIVER), CE Marking, EMC, LVD All components are CE and uL certified
Control	App Hardwired on existing system
Safety	All components must be correctly assembled and connected to maintain the waterproof rating of the system. The assembled MAZU products are officially certified by SGS to meet IP65 ingress protection requirements.

* custom solutions on request, ask us about it!

COMPATIBLE WITH



Casambi
Custom solutions



DALI
Custom solutions



Custom
solutions

